



## Installation Manual

For model N400 - a 4.5 cu. ft., 2-way or 3-way, refrigerator.  
For model N500 - a 5.5 cu. ft., 2-way or 3-way, refrigerator.  
For model N510 - a 5.5 cu. ft., 2-way or 3-way, refrigerator.



**WARNING:** Improper installation, adjustment, alteration, service or maintenance can cause injury or property damage. Refer to this manual. For assistance or additional information, contact a qualified installer, service agency, or the gas supplier.

### FOR YOUR SAFETY

Do not store or use gasoline or other flammable vapors and liquid in the vicinity of this or any other appliance.

### FOR YOUR SAFETY

If you smell gas:

1. Open windows.
2. Don't touch electrical switches.
3. Extinguish any open flame.
4. Immediately call your gas supplier.



**WARNING:** DO NOT install this refrigerator in below deck marine applications. Do not install this refrigerator in fixed indoor cabin or other dwelling applications. This refrigerator must use only NORCOLD designed and approved outside air intake and exhaust ventilation for correct and safe operation. Any other ventilation could cause lethal combustion exhaust fumes and/or explosive propane gas fumes to be in the living area and/or to be below deck.

English

French

NORCOLD, Inc.  
P.O. Box 4248  
Sidney, OH 45365-4248

Norcold Customer Support Dept.  
Telephone: 800-543-1219  
Fax: 937-497-3183  
Web Site: [www.norcold.com](http://www.norcold.com)

## Table of Contents

---

Safety Awareness .....	2
Safety Instructions .....	2
Certification and Code Requirements .....	3
Ventilation Requirements .....	3
Assemble the Enclosure .....	4
Install the Lower and Upper Vents .....	4
Install the Refrigerator .....	5
Installation Options .....	5
Install the decorative door panel .....	5
Reverse the door swing .....	5
Change the travel latch position .....	6
Connect the Electrical Components .....	6
Connect the 120 volt AC supply .....	6
Connect the 12 volt DC supply (models N400.3 and N500.3) .....	7
Connect the 12 volt DC supply (model N510.3) .....	7
Connect the Propane Gas Components .....	8
Connect the propane gas supply system .....	8
Examine the gas supply system for leaks .....	8
Ignition Start Up .....	8
Ignition-propane gas operation (N400 models) .....	8
Ignition-propane gas operation (N500 models) .....	9
Ignition-propane gas operation (N510 models) .....	9

## Safety Awareness

---

Read this manual carefully and understand the contents before you install the refrigerator.

Be aware of possible safety hazards when you see the safety alert symbol on the refrigerator and in this manual. A signal word follows the safety alert symbol and identifies the danger of the hazard. Carefully read the descriptions of these signal words to fully know their meanings. They are for your safety.

 **WARNING:** This signal word means a hazard, which if ignored, can cause dangerous personal injury, death, or much property damage.

 **CAUTION:** This signal word means a hazard, which if ignored, can cause small personal injury or much property damage.

## Safety Instructions

---



### WARNING:

- This refrigerator is equipped for the use of propane gas only and can not be changed to use any other fuels (natural gas, butane, etc.).
- Incorrect installation, adjustment, alteration, or maintenance of this refrigerator can cause personal injury, property damage, or both.
- Obey the instructions in this manual to install the intake and exhaust vents.
- Do not install the refrigerator directly on carpet. Put the refrigerator on a metal or wood panel that extends the full width and depth of the refrigerator.
- Propane gas can ignite and cause an explosion that can result in property damage, personal injury, or death. Do not smoke or create sparks while working on the gas supply system. Do not use an open flame to examine the gas supply piping or fittings for leaks.
- To avoid possible propane gas leaks, always use two wrenches to tighten or loosen the gas supply line connections.
- Make sure the electrical installation obeys all applicable codes. See "Certification and Code Requirements" section.
- Do not bypass or change the refrigerator's electrical components or features.
- Do not spray liquids near electrical outlets, connections, or the refrigerator components. Many liquids are electrically conductive and can cause a shock hazard, electrical shorts, and in some cases fire.
- The refrigerator cooling system is under pressure. Do not try to repair or to recharge a defective cooling system. The cooling system contains sodium chromate. The breathing of certain chromium compounds can cause cancer. The cooling system contents can cause severe skin and eye burns, and can ignite and burn with an intense flame. Do not bend, drop, weld, move, drill, puncture, or hit the cooling system.



### CAUTION:

- The rear of the refrigerator has sharp edges and corners. To prevent cuts or abrasions when working on the refrigerator, use caution and wear cut resistant gloves.

## Certification and Code Requirements

This refrigerator is certified under the latest edition of ANSI Z21.19 Standards by the American Gas Association for installation in mobile homes or recreational vehicles and is approved by the Canadian Gas Association.

The installation must obey these standards and this "Installation Manual" for the NORCOLD limited warranty to be in effect. Installation must agree with local codes. In the absence of local codes, the installation must obey these standards:



Art01290



### In the United States:

- National Fuel Gas Code, ANSI Z223.1.
- Manufactured Home Construction and Safety Standard, Title 24 CFR, Part 32-80.
- Standard for Recreational Vehicles, ANSI A119.2 latest edition.
- For installations which need an electric outlet that is energized by an external power source, the refrigerator must be electrically grounded as written in local or state codes, the National Electrical code, and ANSI/NFPA 70.

### In Canada:

- Current CGA B149.1 and CGA B149.2 Installation Code for Propane Appliances and Equipment.
- Current CSA Z240.4.2 Installation Requirement for Propane Appliances and Equipment in Recreational Vehicles.
- Current CSA Z240.6.2/C22.2 No. 148 Electrical Requirement for Recreational Vehicles.
- When installed, the refrigerator must be electrically grounded as written in the local or state codes, and the Canadian Electrical Code C22.2. Parts 1 and 2.

All propane gas supply piping and fittings must obey local, state, and national codes about type and size. These components must also obey the current NFPA 501C section 2-4, and in Canada, the current CAN 1-6.10 Standard.

## Ventilation Requirements



**WARNING:** The completed installation must:

- Make sure there is sufficient intake of fresh air for combustion.
- Make sure the living space is completely isolated from the combustion system of the refrigerator.
- Make sure there is complete and unrestricted ventilation of the flue exhaust which, in gas mode, can produce carbon monoxide. The breathing of carbon monoxide fumes can cause dizziness, nausea, or in extreme cases, death.
- Make sure the refrigerator is completely isolated from its heat generating components through the correct use of baffles and panel construction.

Certified installation needs one lower intake vent and one upper exhaust vent. Install the upper exhaust vent either through the roof or through the side wall of the vehicle exactly as written in this manual. Any other installation method voids both the certification and the factory warranty of the refrigerator.

The bottom of the opening for the lower intake vent, which is also the service access door, must be even with or immediately below the floor level. This allows any leaking propane gas to escape to the outside and not to collect at floor level.

American Gas Association/Canadian Gas Association (AGA/CGA) certification allows the refrigerator to have zero (0) inch minimum clearance at the sides, rear, top, and bottom. While there are no maximum clearances specified for certification, the following maximum clearances are necessary for correct refrigeration:

Bottom	0 inch min.	0 inch max.
Each Side	0 inch min	1/8 inch max.
Top	0 inch min.	1/4 inch max.
Rear	0 inch min.	1 inch max.

These clearances plus the lower and upper vents cause the natural air draft that is necessary for good refrigeration. Cooler air comes in through the lower intake vent, goes up around the refrigerator coils where it removes the excess heat from the refrigerator components, and goes out through the upper exhaust vent. If this air flow is blocked or decreased, the refrigerator will not cool correctly.

Each NORCOLD model is certified by AGA and CGA for correct ventilation.

## Assemble the Enclosure

---

- Make sure the enclosure is:
  - 36 9/16 inches high x 23 11/16 inches wide x 24 inches deep for N400 models.
  - 42 5/8 inches high x 23 11/16 inches wide x 24 inches deep for N500 and N510 models.
- Make sure the floor is solid and level.
  - The floor must be metal or a wood panel and extend the full width and depth of the enclosure.
  - The floor must be able to support the weight of the refrigerator and its contents.
- Make sure there are no adjacent heat sources such as a furnace vent, etc.

## Install the Lower and Upper Vents

---

1. Using the following chart, decide which vents and rough opening (RO) sizes to use.

Certified Vent	P/N	RO Height	RO Width	Radius
Upper Roof Exhaust Vent	622293	24 in.	5 1/4 in.	none
Upper Side Exhaust Vent	617485	7 1/4 in.	18 in.	none
Lower Side Intake Vent	617484	9 3/4 in.	19 3/8 in.	none
Universal Upper & Lower Vent	620505	6 3/16 in.	17 13/16 in.	none

2. Install the lower intake vent (See Art 01282):

 **WARNING:** Make sure the bottom of the opening of the lower intake vent is even with or immediately below the floor level. This allows any leaking propane gas to escape to the outside and not to collect at floor level.

- Make sure the bottom of the opening of lower intake vent is even with or immediately below the floor level.
  - Align the lower intake vent [1] vertically below the coils [2] and the condenser [3] of the refrigerator.
3. Install the upper exhaust vent (see Art01283):
- If you install the upper side exhaust vent:
    - For N400 models, make sure the distance [4] from the floor level to the top of the rough opening for the upper exhaust vent is at least 41 3/4 inches or poor cooling performance can occur.

- For N500 and N510 models, make sure the distance [4] from the floor level to the top of the rough opening for the upper exhaust vent is at least 47 3/4 inches or poor cooling performance can occur.
- Align the upper exhaust vent [5] vertically above the coils [2] and the condenser [3] of the refrigerator.
- Install a baffle [6] to prevent stagnant hot air in the area [7] above the refrigerator (see Art 01284).
  - Make sure there is less than 1/4 inch clearance [8] between the baffle and the top of the refrigerator.
  - Make sure the baffle is the full width of the inside of the enclosure.
- If you install the roof exhaust vent (see Art 01285):



**CAUTION:** Make sure that no sawdust, insulation, or other construction debris is on the refrigerator or in the enclosure. Debris can cause a combustion hazard and prevent the refrigerator from operating correctly.

**NOTE:** Tighten the screws of the roof cap to 10 inch-pounds max.

- If the design of the vehicle allows, install the roof exhaust vent [9] directly above the condenser [3] of the refrigerator.
  - Install a baffle [10] to prevent stagnant hot air in the area [7] above the refrigerator.
    - Make sure there is less than 1/4 inch clearance [11] between the baffle and the top of the refrigerator.
    - Make sure the baffle is the full width of the inside of the enclosure.
- If the design of the vehicle does not allow you to install the roof exhaust vent directly above the condenser of the refrigerator:
  - Center the roof exhaust vent [9] above the condenser [3] of the refrigerator, but move it inboard as necessary (See Art01286 and Art01287):
  - Install two baffles [12] and [13] to prevent stagnant hot air in the area [7] above the refrigerator.
    - Make sure both baffles are the full width of the inside of the enclosure.
    - Make sure that both baffles are no more than 45° from vertical.
    - Put one baffle between the top rear edge of the refrigerator and the inside edge of the upper exhaust vent opening.
    - Put the other baffle between the outside edge of the upper exhaust vent opening and the side wall of the vehicle.

## Install the Refrigerator

---

1. Make sure the clearance at the rear of the refrigerator is correct:
  - If there is more than 1 inch of clearance between the rear of the refrigerator and the enclosure, install two baffles [14] to the rear of the enclosure (see Art01284 and Art01287).
    - Put one baffle at the top edge of the lower intake vent [1].
    - Put the other baffle at the lower edge of the condenser [3] of the refrigerator.
    - Make sure the baffles are less than 1/4 inch from the coils [2] and condenser of the refrigerator.
      - Make sure the baffles are the full width of the inside of the enclosure.
2. Put the refrigerator in position (see Art01288):

 **WARNING:** Make sure the combustion seal [15] is not broken, is completely around the refrigerator mounting flanges [16], and is between the mounting flanges and the wall of the enclosure. If the combustion seal is not complete, exhaust fumes can be present in the living area of the vehicle. The breathing of exhaust fumes can cause dizziness, nausea, or in extreme cases, death.

- Remove the door from the refrigerator (See "Reverse the door swing" section).
- Put screws through the holes of the refrigerator mounting flanges and into the enclosure wall.
- Attach the door to the refrigerator.
- Put a screw through the holes [17] in the braces at the lower rear corners of the refrigerator and into the floor.

## Installation Options

---

### Install the decorative door panel:

- NOTE: The decorative panels must be 3/16 inch or less in thickness.
- For N400 models, make a decorative door panel [1] that is 31 inches high x 21 5/16 inches wide (See Art00977).
  - For N500 and N510 models, make a decorative door panel [1] that is 37 inches high x 21 5/16 inches wide (See Art00977).
  - Push the decorative door panel into the slots of the door end caps [2].
  - Push each panel retainer [3] into the slot on the edge of the door.

### Reverse the door swing:

This refrigerator has hinges that allow you to change the direction that the door opens by moving the hinges to the opposite corner (See Art01313).

1. Remove the door:
  - Turn out and save the upper hinge pin [1].
  - Open the door a small amount and pull the top of the door away from the upper hinge of the refrigerator.
  - Lift the door off of the lower hinge pin [2].
  - Turn out and save the lower hinge pin.
2. Change the position of the hinges:
  - Remove the screws from the upper hinge [3].
  - Put this hinge on the other side as the lower hinge.
  - Attach the hinge with the screws.
  - Turn the lower hinge pin down into this hinge.
  - Remove the screws from the lower hinge [4].
  - Remove the screws from the travel latch [5].
  - Put this hinge on the other side as the upper hinge.
  - Attach the hinge with the screws.
3. Change the position of the travel latch (See Art01313 and Art01571):
  - Put the travel latch on the other side of the refrigerator.
  - Attach the travel latch with the screws.
  - Remove the screw [6] from the travel latch plate [7] on the door.
  - Remove the screw [6] from the filler plate [8] on the door.
  - Put the travel latch plate on the other side of the door.
  - Attach the travel latch plate with the screw.
  - Put the filler plate on the other side of the door.
  - Attach the filler plate with the screw.

#### 4. Install the door:

- Put the door down onto the lower hinge pin.
- Align the holes in the upper hinge and the filler plate and hold in this position.
- Screw the upper hinge pin down into the upper hinge and into the door.
- Tighten all of the screws.
- Make sure the travel latch fully engages the travel latch plate.
  - The travel latch should engage the travel latch plate .2 inches.
  - If not, loosen the screws and adjust the height of the travel latch.
  - Tighten the screws.

#### Change the travel latch position:

This refrigerator allows you to put the travel latch either at the top of the door or at the bottom of the door regardless of the door swing direction (See Art01570 and Art01572).

1. Change the position of the travel latch plate:
  - Remove the screw [6] from the travel latch plate [7] on the door.
  - Remove the screw [6] from the filler plate [8] on the opposite end of the door.
  - Put the travel latch plate on the opposite end of the door.
  - Attach the travel latch plate with the screw.
  - Put the filler plate on the opposite end of the door.
  - Attach the filler plate with the screw.
2. Change the position of the travel latch:
  - Remove the screws from the travel latch [5].
  - Put the travel latch on the opposite end of the refrigerator.
  - Attach the travel latch with the screws.

## Connect the Electrical Components

NOTE: The current draws are nominal values.

N400 models	
AC Operation	120 volts AC voltage (108 volts min. - 132 volts max.)
Current Draw	1.8 Amps at 110 volts AC 2.0 Amps at 120 volts AC
Propane Gas Operation	
Current Draw	12 volts DC control voltage (11.5 volts min. - 15.4 volts max.) .37 Amps at 12 volts DC .42 Amps at 15 volts DC
DC Operation (N400.3 only)	
Current Draw	12 volts DC 14.1 Amps at 12 volts DC 16.5 Amps at 14 volts DC
N500 models	
AC Operation	120 volts AC voltage (108 volts min. - 132 volts max.)
Current Draw	1.8 Amps at 110 volts AC 2.0 Amps at 120 volts AC
Propane Gas Operation	
Current Draw	12 volts DC control voltage (11.5 volts min. - 15.4 volts max.) .13 Amps at 12 volts DC .15 Amps at 14 volts DC
DC Operation (N500.3 only)	
Current Draw	12 volts DC voltage (11.5 volts min. - 15.4 volts max.) 14.1 Amps at 12 volts DC 16.5 Amps at 14 volts DC
N510 models	
AC Operation	120 volts AC voltage (108 volts min. - 132 volts max.) 12 volts DC control voltage (10.5 volts min. - 15.4 volts max.)
Current Draw	1.79 Amps at 110 volts AC 1.92 Amps at 120 volts AC
Propane Gas Operation	
Current Draw	12 volts DC control voltage (11.5 volts min. - 15.4 volts max.) .37 Amps at 12 volts DC .42 Amps at 15 volts DC
DC Operation (N510.3 only)	
Current Draw	12 volts DC control voltage (10.5 volts min. - 15.4 volts max.) 14.1 Amps at 12 volts DC 17.0 Amps at 15 volts DC

This refrigerator operates on both AC and DC electrical sources. Operation out of these limits may damage the refrigerator's electrical circuit parts and will void the warranty.

#### Connect the 120 volt AC supply:



**WARNING:** Connect the AC power cord only to a grounded three-prong receptacle. Do not remove the round ground prong from the power cord. Do not use a two-prong adapter or an extension cord. Operation of the refrigerator without correct ground can cause dangerous electrical shock or death if you are touching the metal parts of the refrigerator.

Put the AC power cord into a grounded three-prong receptacle:

- Make sure the receptacle is positioned within easy reach of the lower intake vent.
- Make sure the power cord does not touch the burner cover, the flue pipe, or any hot component that could damage the insulation of the power cord.

### Connect the 12 volt DC supply (models N400.3 and N500.3):

As the distance from the vehicle battery to the refrigerator increases, the correct AWG wire size and fuse size also increases. If the wire size is too small for the distance, a voltage drop occurs. The voltage drop decreases the output of the system heater and causes poor cooling performance.

1. Find the correct min. wire size and the max. fuse size to use:



**WARNING:** Use only the recommended wire and fuse size.

- If the distance is 0 - 20 feet, use a minimum of 10 AWG wire and a 30 amp max. fuse.
- If the distance is over 20 feet, use a minimum of 8 AWG wire size and a 40 amp max. fuse.
- If the wire is larger than the min. size, use the correct fuse per RVIA A119.2 standard or local codes.

The wire connections must be clean, tight and free of corrosion. If any of these items are not correct:

- A voltage drop to the refrigerator will occur.
- The voltage drop will reduce the cooling performance of the refrigerator.

The terminals for connecting the DC power supply are marked positive (+) and negative (-) on the terminal block of the refrigerator. Make sure that:

- Each DC power supply wire is attached to the correct polarity terminal.
- The chassis or the vehicle frame is not used as one of the conductors.
- The DC power supply wires including the fuses are routed directly from the battery to the refrigerator.

2. Connect the D.C. power supply wires:

- Attach a 1/4 inch Quick Connect terminal to each DC power supply wire.
- Push each power wire onto the terminal block [1] at the rear of the refrigerator (See Art00975).
- Make sure each DC power supply wire is on the correct polarity terminal.

### Connect the 12 volts DC supply (model N510.3):

As the distance from the vehicle battery to the refrigerator increases, the correct AWG wire size and fuse size also increases. If the wire size is too small for the distance, a voltage drop occurs. The voltage drop decreases the output of the system heater and causes poor cooling performance.

1. Determine the min. wire size and the max. fuse size to use:



**WARNING:** If you use an incorrect wire size and/or fuse size, electrical fire can result.

- On 2-way models, use a minimum of 18 AWG wire and a maximum 6 Amp fuse.
- On 3-way models, measure the distance from the vehicle battery to the refrigerator.
  - If the distance is 0 - 20 feet, use a minimum of 10 AWG wire and a maximum 30 Amp fuse.
  - If the distance is over 20 feet, use a minimum of 8 AWG wire and a maximum 40 Amp fuse.
- If the wire size is larger than the min. size, use the correct fuse per RVIA A119.2 standard or local codes.

2. Install a fuse in DC power supply wires between the battery and the refrigerator:

- Put fuse as close to the battery as possible.

3. Connect the DC power supply wires:

- Attach a 1/4 inch Quick Connect terminal to each DC power supply wire.

**NOTE:** Do not use the chassis of the refrigerator or the vehicle frame as one of the conductors. Attach the DC power supply wires only to the battery and the power board [1] of the refrigerator.

- Push the positive DC power wire onto the power board terminal that is marked 12VDC.
- Push the DC ground wire onto the power board terminal that is marked 12V GND1.
- Make sure each DC power supply wire is on the correct polarity terminal.

## Connect the Propane Gas Components

This refrigerator operates on propane gas at a pressure of 11 inches Water Column Propane.

### Connect the propane gas supply system:

**WARNING:** Be very careful when working on or near the propane gas system.

- Do not smoke or use an open flame near the propane gas system.
- Do not use an open flame to examine for leaks.
- Do not connect the refrigerator to the propane gas tank without a pressure regulator between them.
- To avoid a propane gas leak, always use two wrenches to tighten or loosen the gas supply line connections.
- Leaking propane gas can ignite or explode and result in dangerous personal injury or death.

Connect the gas supply line to the refrigerator:

- Make sure all tubing and fittings obey all local, state, and national codes about size and type.
- Make sure that all flexible metal connectors obey the current CAN1-6.10 Standard.
- Use 3/8" diameter copper tubing as the propane gas supply line and use a 3/8" SAE (UNF5/8 -18) female flare fitting as the connection to the refrigerator.
- Put the gas supply line up through the floor of the enclosure and in a manner to prevent vibration and abrasion.
- Make sure the hole through the floor is large enough to allow clearance for the gas supply line.
- Put a weather resistant seal (grommet, sealant, etc.) around the gas supply line where it goes through the floor to prevent vibration and abrasion.
- Attach the gas supply line to the bulkhead fitting [2] of the refrigerator (See Art00975).

### Examine the gas supply system for leaks:

**WARNING:** Do not allow the leak detecting solution to touch the electrical components. Many liquids are electrically conductive and can cause a shock hazard, electrical shorts, and in some cases, fire.

Use a solution of liquid detergent and water to examine the gas supply line and all gas connections for leaks.

If you use compressed air for the test:

- The pressure at the manual shut off valve of the refrigerator must not be more than 1/2 psig (14 inches Water Column).
- If the air pressure is more than 1/2 psig (14 inches Water Column), remove the gas supply line from the bulkhead fitting of the refrigerator before the test.
- If the air pressure is equal to or less than 1/2 psig (14 inches Water Column), close the manual shutoff valve of the refrigerator before the test.

## Ignition Start Up

### Ignition - propane gas operation (N400 models):

1. Open the valve at the propane gas storage tank.

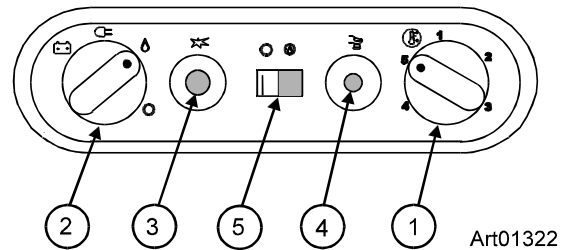

2. Turn the thermostat [1] to the 5 position.
3. Turn the selector switch [2] to the propane gas position (  ).
4. Push and hold in the safety valve [4] and push in the igniter [3] several times in rapid succession, for about five seconds:

**WARNING:** Do not hold in the safety valve for more than 30 seconds. If there is no flame in this time, wait at least five minutes before you try ignition again. If you continue to hold in the safety valve, gas will collect in the burner area. This could cause a fire or explosion and result in dangerous personal injury or death.

- When a flame is present and the flame meter [5] moves into the green area, release the safety valve.
  - If the flame meter does not move into the green area, do this step again.
5. Turn the thermostat to the temperature setting that you wish.



### Ignition - propane gas operation (N500 models):

1. Open the valve at the propane gas storage tank.

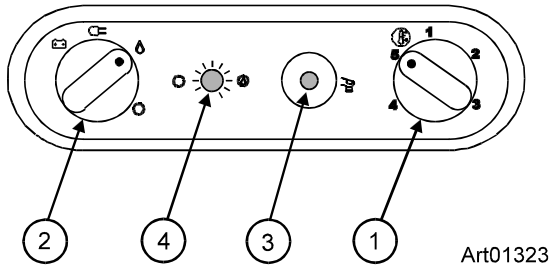

2. Turn the thermostat [1] to the 5 position.
  3. Turn the selector switch [2] to the propane gas position ( 🔥 ).
  4. Push and hold in the safety valve [3] for about five seconds:
    - The refrigerator automatically ignites the gas at the burner.
- ⚠️ WARNING:** Do not hold in the safety valve for more than 30 seconds. If there is no flame in this time, wait at least five minutes before you try ignition again. If you continue to hold in the safety valve, gas will collect in the burner area. This could cause a fire or explosion and result in dangerous personal injury or death.
- When a flame is present and the flame indicator [4] illuminates, release the safety valve.
  - If the flame indicator does not illuminate, do this step again.
5. Turn the thermostat to the temperature setting that you wish.

### Start up - AC operation:

- Make sure that 120 volts AC is available.
- Turn the selector switch to the AC position ( ⏏ ).
- Turn the thermostat to the temperature setting that you wish.

### Start up - DC operation (3-way model N500.3):

- Make sure that 12 volts DC is available.
- Turn the selector switch to the DC position ( 🔌 ).

### Shut down:

- Turn the selector switch to the OFF position ( ⏻ ).

### Ignition - propane gas operation (N510 models):

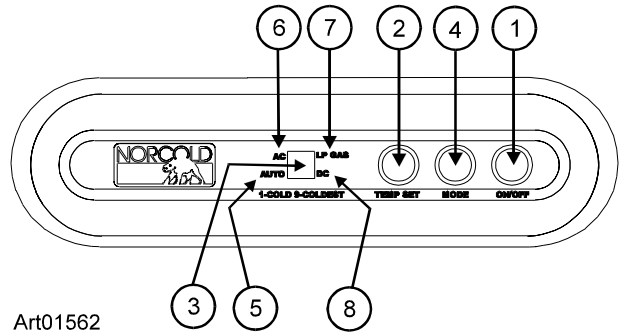

Press the ON / OFF button to start the refrigerator in auto mode.

- Push and hold the MODE button until the light bar flashes in the center display beside LP GAS.
- Release the MODE button.

NOTE: On initial start up of the refrigerator, ignition of the propane gas may not occur within 30 seconds.

If ignition of the propane gas does not occur within 30 seconds:

- The gas safety valve of the refrigerator closes.
- The refrigerator stops operation.
- Refer to the "Fault Codes" section of this manual.
- The fault code remains until you push the ON / OFF button two times (to stop and start the refrigerator).
- If ignition does not occur after two or three times:
  - Check the gas supply line.
  - Consult your local dealer or an authorized Norcold Service Center.
  - Change to manual mode and operate on AC electric.

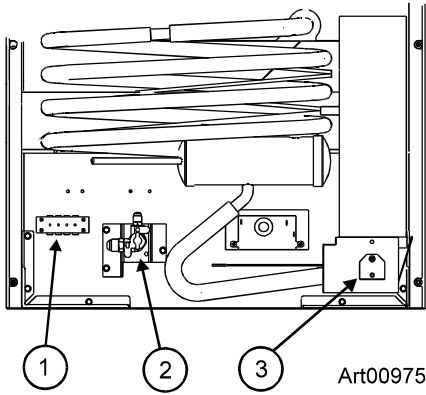

Art00975

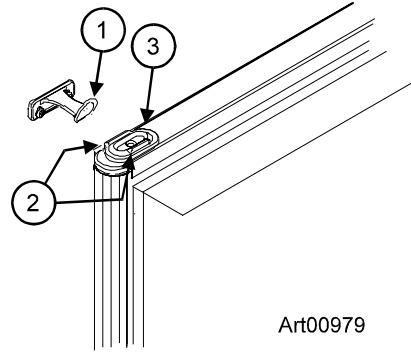

Art00979

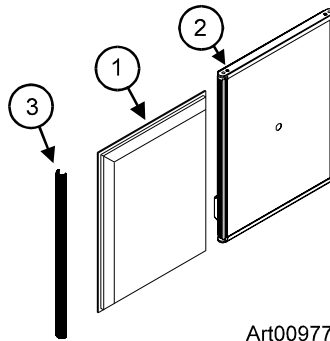

Art00977

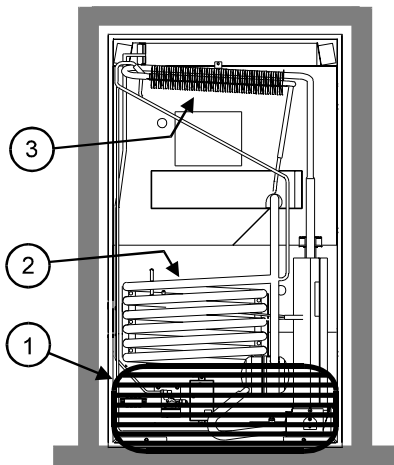

Art01282

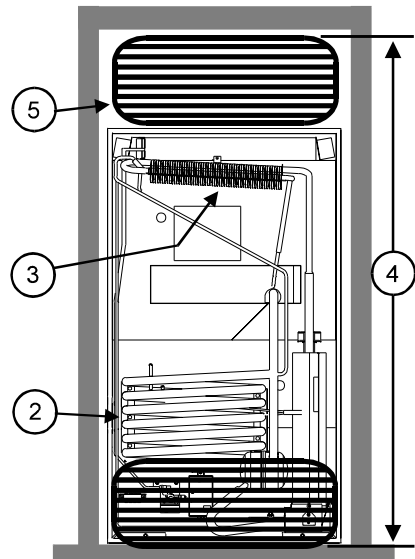

Art01283

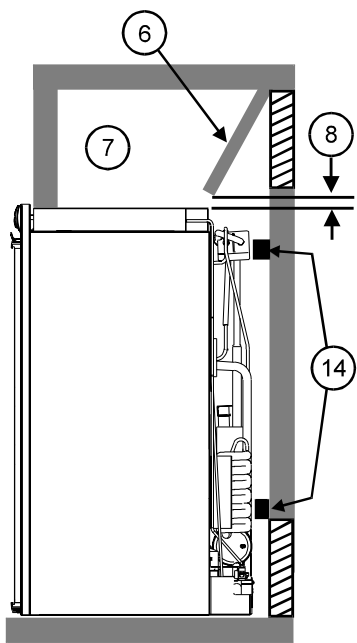

Art01284

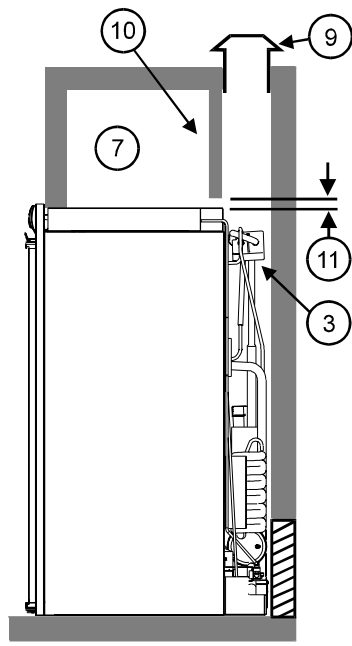

Art01285

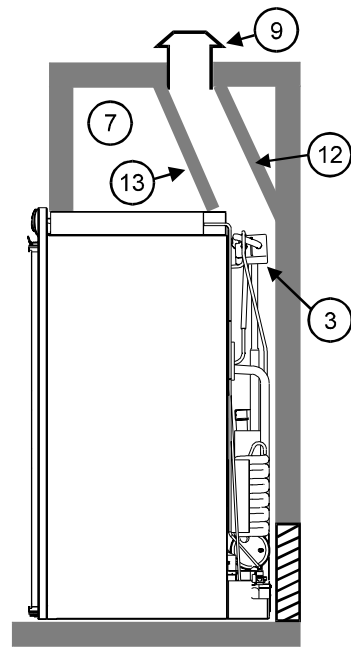

Art01286

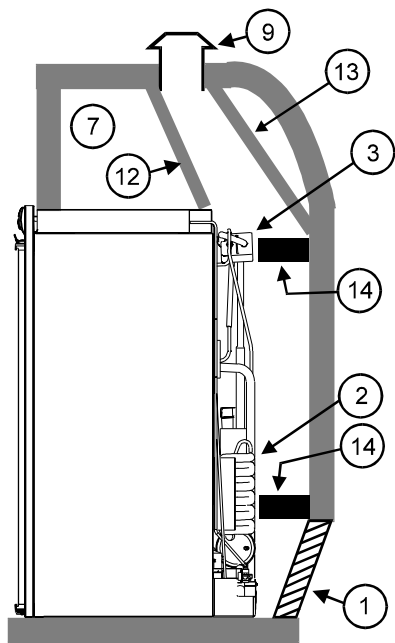

Art01287

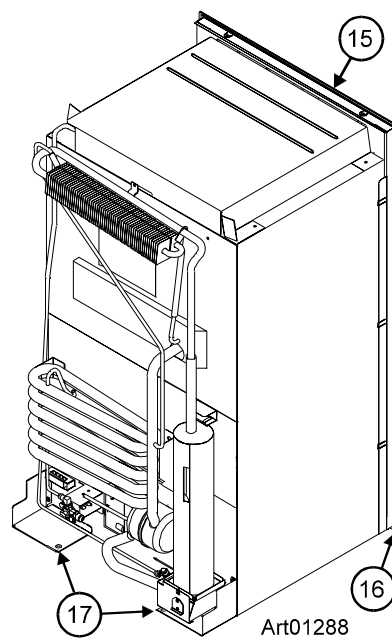

Art01288

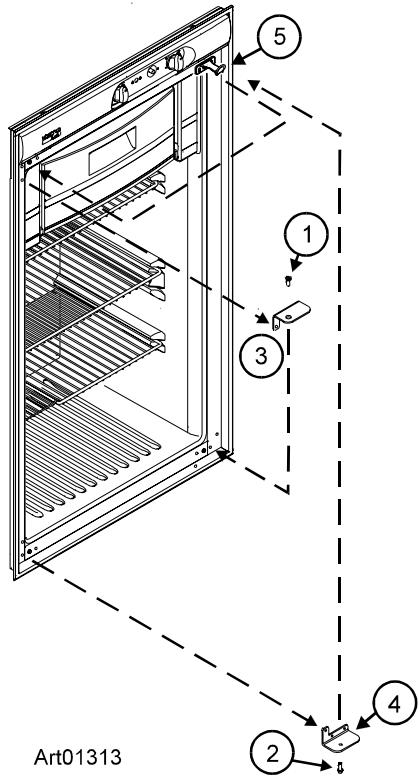

Art01313

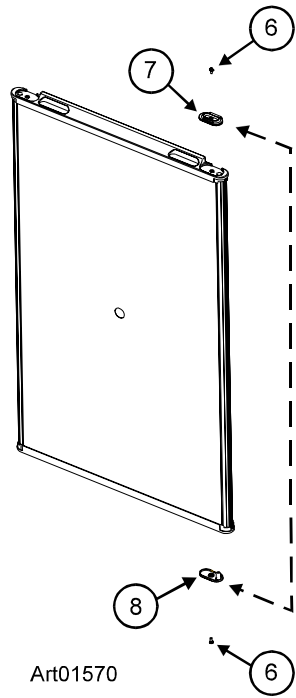

Art01570

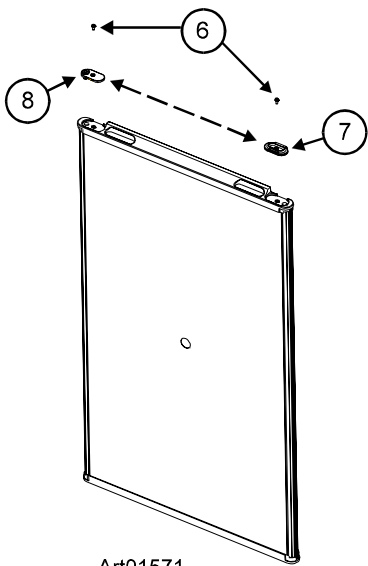

Art01571

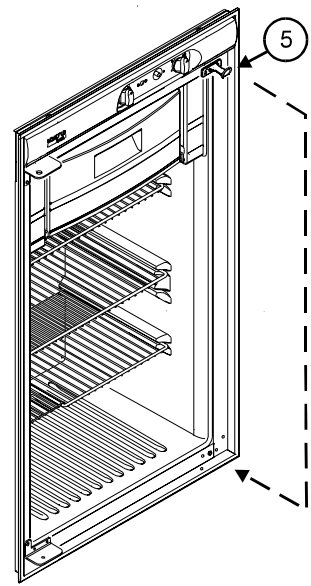

Art01572