

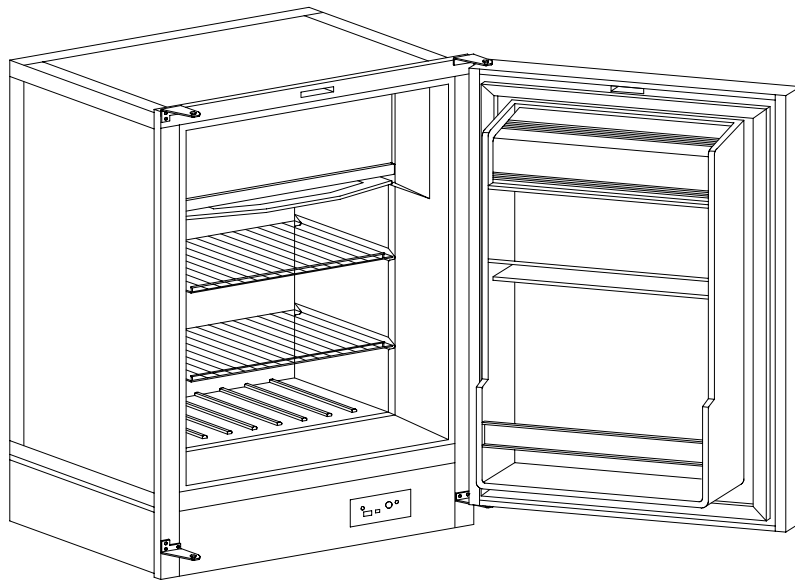

OWNER'S MANUAL

MODEL DE-704D





Model DE-704D

EXTENDED COOLING UNIT SERVICE PROTECTION PLAN

An additional two year Service Contract is now available to original purchasers of Norcold refrigerators. For only \$25.00 you get:

- * two extra years protection against cooling unit failure
- * automatic replacement of defective cooling unit
- * pre-paid freight from your dealer to Norcold and return
- * labor free of charge

The E.S.P. (Extended Service Plan) plan can be obtained by mailing your check for \$25.00, U.S. funds to:

**Norcold
P.O. Box 180
Sidney, OH 45365**

If mailing in Canada:
GREG LUND PRODUCTS, LTD.
P.O. Box 760
Oakville, Ontario, Canada L6J 5C4

E.S.P. is a service contract between Norcold and the original purchaser. The contract provides replacement of a defective cooling unit only for this refrigerator (freight, parts and labor) for an additional period of two years after expiration of the original Limited Warranty. The refrigerator must be delivered to a Norcold service center together with the Norcold E.S.P. card showing E.S.P. coverage. An E.S.P. card will be mailed to the original purchaser upon receipt of a completed Extended Service Protection Plan Application form and a check covering the E.S.P. charge. E.S.P coverage is non-transferable and non-refundable.

To register your refrigerator, fill out the Extended Service Protection Plan Application - i.e.: tear sheet form in blue envelope or include the following information (Please Print Clearly):

1. Owner's name and address
2. Refrigerator model number
3. Refrigerator serial number
4. Date of purchase
5. Check for \$25.00 (payable to Norcold)

Applications will be accepted only if they are mailed within ninety (90) days after date of purchase.

IMPORTANT

This refrigerator is designed to operate on power supply limits as follows:

120 volt AC operation: 132 volts max., 108 volts min.
61 hertz max., 59 hertz min.

12 volt DC operation: 15.4 volts max., 12 volts min.

Operation on power supplies exceeding the maximum limits may cause damage and void the warranty. Operation on power supplies below the limits will result in unacceptable performance.

When operating on 12 volts DC, a battery source must be used. Operating the refrigerator on a convertor or battery charger alone (without a battery in the circuit) is not recommended since these devices do not normally supply a filtered DC source. Unsatisfactory operation will result.

This appliance has been designed for refrigerating purposes and is operable on either 120 volt AC or 12 volt DC when installed as directed by this manual.

The location of the model and serial number may be found attached to the front bottom trim or on the cabinet liner immediately adjacent to the trim rail. (See Figure 1.)

Before installing your refrigerator, record and retain the model and serial number for future reference and warranty purposes.

Model No. DE-704D

Serial No. _____

Date Of Purchase _____

Dealer's Name _____

INSTALLATION

In preparing the DE-704D for installation, the following areas should be considered:

1. Adequate ventilation.
2. Sizing of supply wire and fuse protection.
3. Direct wiring from battery to avoid electrical interference with other equipment.
4. Provisions to prevent battery run-down.
5. Provide correct voltage and frequency for AC operation.
6. Proper grounding to prevent electrolysis for marine applications.

These instructions provide a guide to insure compliance to the situations listed above.

The Norcold dual voltage refrigerator is designed for the recreational vehicle, Marine industry, as well as under the counter installations. A typical R.V. installation, for instance, requires the refrigerator to operate on 12 volt DC while in transit and 120 volt AC while parked. The Norcold refrigerator automatically converts from one power source to the other.

Unlike the absorption-type refrigerator, which requires a constant heat source for efficient operation, your dual voltage refrigerator operates on the same principle as the standard domestic refrigerator. That is, it has an electrically operated compressor and uses freon as its refrigerating medium.

Unit Location

Be sure the refrigerator is not installed in direct sunlight, or near a gas stove, heater or other heat generating sources. A flanged mounting frame is provided around the front of the refrigerator cabinet to allow build-in installation.

The refrigerator must be located and secured on a solid surface within the vehicle.

The opening cut-out dimensions for the refrigerator are listed in Table 1. Measure for the opening and determine if you have the proper clearances for installation. There is no need for allowing an area around the cabinet for additional insulation as the Norcold refrigerator is well insulated and requires no additional insulation.

Table 1

Refrigerator Cut-Out Opening (inches)

| Model | Height | Width | Depth |
|---------|--------|-------|--------|
| DE-704D | 33 1/8 | 22 | 21 3/4 |

Before installing the cabinet into the opening, check to see if the AC power supply cord of the unit is properly connected to the AC wall outlet and if the DC supply should be connected. In many cases, the DC supply can be connected from outside the vehicle by means of the vent or access door.

Place the refrigerator into the wall opening and secure it in place by fastening the mounting flange to the wall through the holes provided.

Please note the perforated access panel at the front base of the refrigerator. This panel allows air movement to flow under the cabinet and over the power supply for cooling.

The rear side of the unit must not be closed off without providing ventilation. At least 50 sq. inches must be provided to allow rejected heat to escape.

For travel trailers, a small louver-type vent of approximately 4" x 16" area may be installed at the top and at the bottom of the exterior wall of the vehicle for outside venting purposes.

A combination of a roof jack and lower vent or two side vents offers adequate venting for high outside ambient temperatures. The more air circulating over the condenser (located at rear), the more efficient the refrigerator will operate. Failure to provide the

necessary ventilation will result in poor refrigeration. If operation at low outside ambient temperatures is necessary (below 23° F) all exterior venting must be covered to prevent serious performance loss.

When installation incorporates exterior venting and operation at low outside ambient temperatures is necessary (below 23° F), exterior venting must be covered or reduced cooling efficiency in cabinet will result.

Power Supply

Provisions are made for connection of either 12 volts DC or 120 volts AC to the refrigerator. If both 12 volts DC and 120 volts AC are simultaneously supplied, a special relay in the refrigerator power supply allows the unit to run on 120 volts AC. To convert to DC power, the AC supply is simply disconnected.

DC Power Connection

The DC supply connection is located behind the perforated access panel at the bottom front of the unit. Remove the screw from the top center of the access panel and remove the panel. The DC terminal box is located in the control power supply assembly. The positive and negative DC supply connections are located in this terminal box. The terminal box is provided with knock-out holes for routing the DC lead wires through the side of the terminal box.

The size of the wire from your 12 volt DC battery is dependent upon the distance between the refrigerator and the battery. Refer to Table 2 for wire size.

Table 2

12 Volt Supply Wiring And Fuse Size

| | Min. Wire Size | Max. Fuse Size |
|-----------|----------------|----------------|
| 0 -12' | 14 AWG | 15 AMP |
| 12' - 20' | 12 AWG | 15 AMP |
| over 20' | 10 AWG | 15 AMP |

This recommended wire size is to prevent a voltage drop at the refrigerator which is critical to DC performance.

Use of wire sizes smaller than those listed may cause excessive DC running time, shorter battery life, and poor performance due to line loss.

It is important that the 12 volt, DC supply wires be connected directly to the battery and that the wires are dedicated to the refrigerator (other appliances are connected by separate wires). This practice minimizes the possibility of radio and T.V. interference. Twisting the positive and negative supply wires further helps to nullify the induction effects which could further add to radio/T.V. interference.

To the leads located in the terminal box, connect the positive battery lead to the red wire and the negative battery lead to the black wire (important to be well insulated). These splices should be soldered or connected by means of an approved splice connector. Tape the spliced connections generously before replacing the terminal cover box.

A 15 amp fuse should be installed as close to the battery as possible in the positive wire leading to the refrigerator. This fuse will protect the wiring from the battery to the refrigerator in the event of a short circuit.

CAUTION:

DO NOT OPERATE REFRIGERATOR ON BATTERY ALONE. THE BATTERY MUST HAVE A CHARGING MEANS SUCH AS AN ON-BOARD GENERATOR; IF NOT, THE BATTERY WILL DISCHARGE IN A SHORT PERIOD OF TIME.

Further information on DC supplies can be found later in this manual.

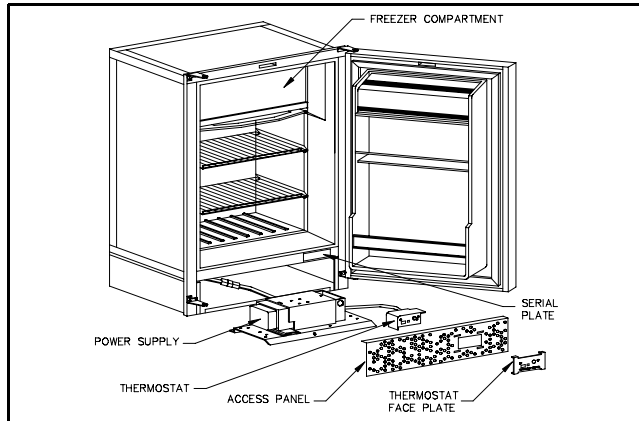

Figure 1

AC Power Connection

The 120 volt AC power connection is made by connecting the refrigerator's AC cord to a standard 120 volt grounded receptacle. See Figure 2.

The 120 volt AC supply wires, to which the refrigerator is connected, should be routed through the fuse panel or circuit breaker that protects the vehicle when an outside power source is used. This connection should be permanently wired in accord-

ance with existing governing codes. The use of an extension cord is not recommended.

CAUTION:

IF AC POWER IS SUPPLIED BY AN ON-BOARD GENERATOR, IT IS VERY IMPORTANT TO HOLD BOTH VOLTAGE AND FREQUENCY WITHIN THE TOLERANCES STATED IN THE FRONT OF THIS MANUAL

Special Requirements For Marine Installations:

The DE-704D is internally wired so that the AC and DC circuits are isolated from each other. If the positive (+12 volts) DC input is grounded in any way (cuts in the wire insulation, improperly insulated connections, etc.), a voltage potential could be developed throughout the boat in which corrosion develops on any metal parts exposed to water.

This situation may be avoided by wiring the boat so that AC and DC grounds are common and wiring is protected per NNMA CERTIFICATION HANDBOOK (1987). Inspect all wiring to insure that insulation has not been damaged. Plastic wire clamps are recommended.

To obtain more information on corrosion, a good reference is:

BOAT AND YACHT CORROSION CONTROL
by Yacht Corrosion Consultants, Inc.
2368 Eastman Ave. #6, Ventura, Ca. 93003.

OPERATION

Power Source

As previously noted, the Norcold refrigerator can be operated on either 12 volts DC or 120 volts AC. If both power sources are connected simultaneously, the refrigerator will operate on 120 volts AC. A special relay disconnects the DC power. To operate on DC power, the AC source must be disconnected, allowing the relay to switch to 12 volts DC.

On DC operation the circuit is protected electronically for over-current and overvoltage. Likewise on AC operation the circuit is protected from overload conditions by a bi-metallic current limiting device.

Temperature Control

A single thermostat controls the operation of the refrigerator on AC or DC. It is located on the panel below the front door (See Fig. 1). The dial is marked "1" through "5". The nearer the dial is set to "5", the colder the temperature becomes in the cabinet.

There is no need to readjust the setting of the thermostat for dual operation. Once the desired temperature is reached, the thermostat will control the cabinet temperature equally well on either voltage supply.

Initial Start-up

Before operating the refrigerator for the first time, check to see that the AC and DC supply connections are correct. If normal, the green power indicator will be illuminated. Connect the vehicle to the external power supply of 120 volts. Turn the switch located next to the thermostat to the "ON" position. Turn the thermostat dial to the number "3" setting. The unit should be operating. You can hear the compressor sound by placing your ear next to the refrigerator.

Allow approximately five minutes of operation and open the freezer compartment door. Place your hand at the upper left rear corner of the cooling plate. This is the area of the plate that will begin cooling first. If you notice a cooling effect at this point, then the unit is functioning properly.

Close the refrigerator door and allow the refrigerator to operate on AC until it cycles or shuts itself off. This indicates the thermostat is operating and that the refrigerator is cooling on AC operation.

Now, disconnect the AC supply and open the refrigerator door so that the cabinet interior will warm up and allow the thermostat to demand cooling.

As soon as the unit's compressor begins to operate, close the refrigerator door, allowing the unit to run. It should shut off or cycle within 10 to 20 minutes indicating the DC operation is correct.

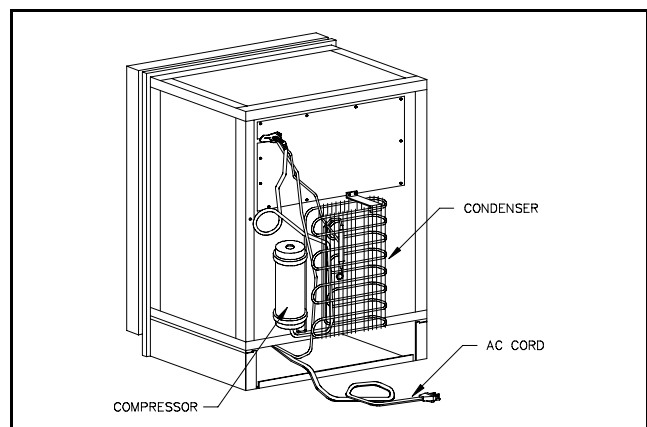

Figure 2

MAINTENANCE OF YOUR REFRIGERATOR

Cleaning Cabinet and Door

Wipe with a soft, dry cloth. To remove dirt, use a cloth moistened by a warm neutral detergent solution. Never use hot water. After cleaning, wipe with a dry cloth.

CAUTION:

Never use a brush, powder soap, cleanser, acid, benzene, gasoline, or thinner. These tend to leave scratches on the coating.

Gasket (door cushion)

Wipe away dirt with a soft cloth moistened by a neutral detergent. Do not soak the cloth excessively. If water gets inside, the insulating effect may become temporarily impaired.

Attachments

Wash all attachments in soap suds. Rinse and wipe clean with a dry cloth.

To Turn Off The Refrigerator

If you will not be using the refrigerator for a day or two, turn the thermostat knob to "1". For a longer period, set the On-Off switch to "OFF" and disconnect power by removing the AC plug from its socket. Also, disconnect the DC power from its source.

When not in use, the refrigerator should be emptied, cleaned, and dried, and the door left ajar.

Defrosting

Set the On-Off switch to "OFF". When frost is melted, wipe the compartment plates with a soft, dry cloth. A better suggestion is to set the dial to "1" before you retire for the night. The frost will be gone the next morning.

Do not use sharp objects to chip ice from the cooling plates.

Information on battery power

The battery power required for the operation of the refrigerator is dependent upon the number of DC appliances being used, the type of operation desired and cycling pattern desired.

A battery must also be sufficiently charged to prevent overdraw.

A battery is rated usually in ampere-hours; that is, it is capable of sustaining its rated ampere capacity for a period of one hour.

If the total amperage load of the vehicle is high (25 amperes), then the installation of a 72 ampere-hour battery will not provide the required power for any length of time unless it is aided by a recharging source such as an alternator or generator.

Various load requirements of the vehicle's DC system dictate the ampere-hour capacity that should be installed.

Refer to Figure 3 for the suggested dual-battery wiring diagram. You will note that in this diagram there are 2 separate battery sources. One source is the vehicle or car battery used exclusively for the operation of the engine and accessory equipment such as head lights. The other source is for the operation of the DC appliances within the recreational vehicle or boat. This battery source is referred to as the accessory or house battery and is used solely for that purpose.

Both of these battery sources are charged by one alternator or generator which is powered by the vehicle engine. This charging device should be of adequate amperage rating so that a short engine run will bring the batteries up to full charge. The standard alternator has a minimum rating of 60 amperes.

Check your voltage regulator or cut-out for correct charging level. Voltage should be 13.5 to 14.5 volts to the battery.

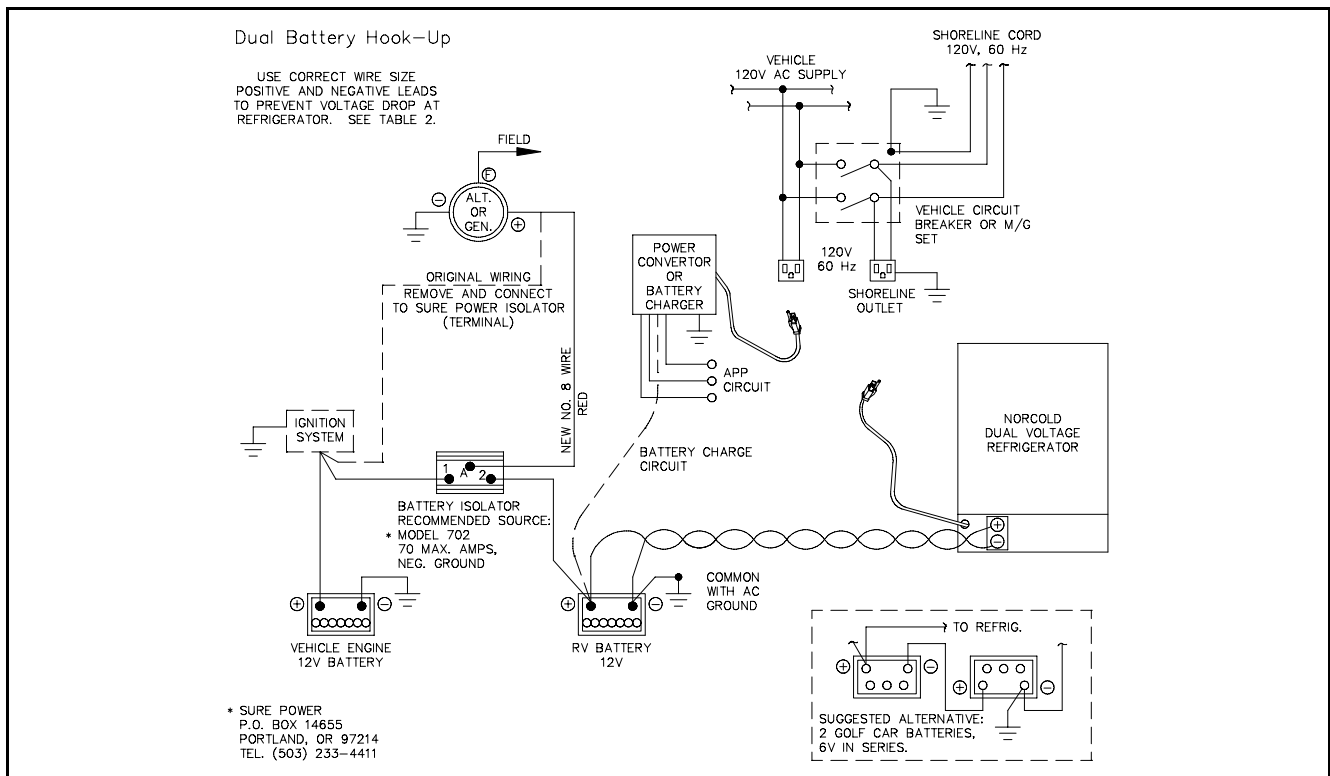

Figure 3

Important Points Regarding Battery-Powered Sources

The dual battery switch or battery isolator is an important component as it permits the alternator or generator to charge both the accessory battery and the vehicle battery during operation of the vehicle engine. However, it limits the current draw of the DC appliances to the accessory battery source when the engine or vehicle is idle or stopped. Thus it assures that the vehicle battery is fully charged for starting the engine. The batteries referred to in Figure 3 are two 6 volt golf cart batteries connected in series to provide 12 volts. Golf cart batteries are suggested for the following reasons:

1. Larger plate construction.
2. Deep draw characteristics.
3. High ampere-hour rating.

The standard golf cart battery has a rating of approximately 185-205 ampere-hours. When two of these batteries are connected in series, the result is 12 volt DC at 185 or 205 ampere-hour capacity.

The DC supply to the refrigerator is connected to the negative post of one battery and to the positive post of the other battery.

The power converter or solid state battery charger shown in Figure 3 is an essential item for battery-operated systems.

The converter is operated on 120 volt AC and should have an output rating of 12.6-14.5 volts DC at approximately 20-50 ampere capacity. During 120 volt operation, the converter is used to charge the batteries and to operate the DC appliances. It has the capacity to operate items such as lighting, water pumps, exhaust fans, and sanitary facilities while maintaining or charging the batteries. Charging rate varies from 5-20 amperes per hour.

The Norcold dual voltage refrigerator automatically switches from AC to DC or from DC to AC. When a power supply of 120 volts AC is connected to the vehicle, the voltage selection relay is energized and disconnects the unit from DC operation. This unique feature assures 120 volt operation when available and permits the power converter to concentrate its charging facilities to the batteries or to other DC appliances.

When the AC supply is disconnected, the refrigerator automatically reverts to DC operation. Setting the On-Off switch to the "OFF" position will prevent operation on AC or DC.

The following are suggestions for efficient operation of the refrigerator:

1. The thermostat dial is numbered from 1 through 5, with the number 5 setting the maximum coldest position. In order to conserve battery power, it is advisable to set the thermostat dial at the lowest setting that will provide adequate refrigeration. This practice will reduce the running time of the refrigerator and draw less current from the battery. A setting of 2 or 3 is a normal position.
2. Always operate the refrigerator on 120 volts AC when available, especially during initial start-up or pull-down cycle of the refrigerator. Depending upon the ambient temperature, the initial start-up may require 1-2 hours of continuous operation before refrigerator temperature are attained and unit cycling begins.
3. Never employ "quick-chargers" to the battery unless the On-Off switch is set to the "OFF" position or the 12-volt DC leads to the refrigerator are disconnected. Possible inverter damage will occur if the high voltage of "quick chargers" is permitted to energize the DC circuits of the inverter.
4. The use of a commercial 12-volt DC to 120-volt DC solid state inverter, converter, gasoline or belt-driven generator with 120 volt AC output is not recommended for operating the refrigerator unless the manufacture of the forementioned devices guarantee the output voltage to be 120 volts AC plus or minus 10 percent and the frequency to be 60 hertz plus or minus one hertz. Devices that cannot meet the specified tolerances do not hold the required frequency,

provide poor performance of the refrigerator, and damage the resonance springs in the compressor.

5. When connecting the refrigerator to the DC supply, observe the correct polarity. If the polarity is reversed (positive connected to negative terminal), the circuit protection will shut the unit down. The wire leads must be disconnected and reconnected properly, and circuit breaker reset.

Installation Of Decorator Panel

Prepare the panel by cutting to size as per illustration. Use dimensions shown in Figure 4. The maximum panel thickness must not exceed 3/16" (4.76mm).

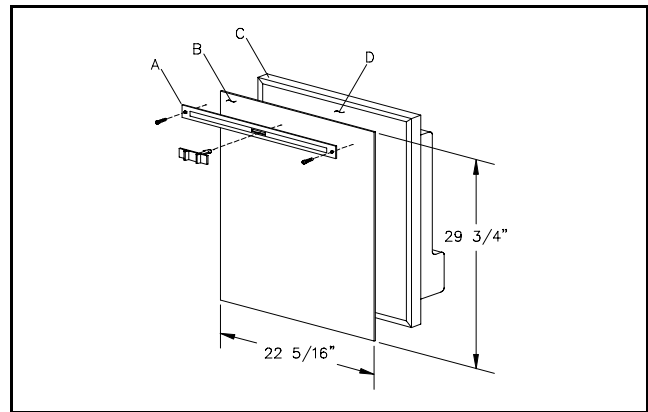
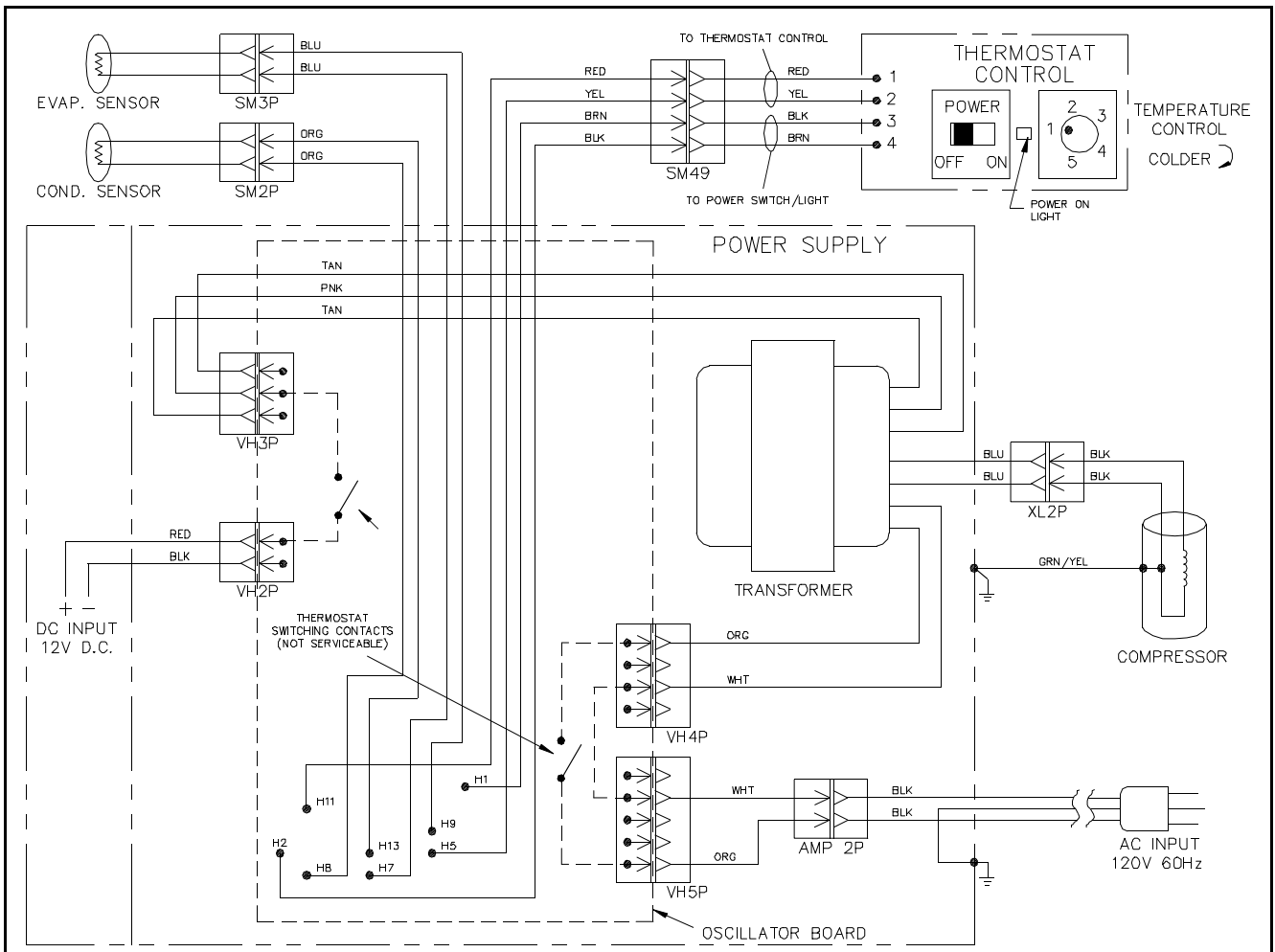

Figure 4

1. Remove the door front decorative strip by removing the screws and pulling the decorative strip off.
2. Insert one of the vertical sides of the panel (B) into the groove formed by the door frame outer flange (C) and the door front.
3. Gently flex the panel (B) so that the opposite side may be slipped into the corresponding groove.
4. Slide the panel (B) downward so that the lower horizontal edge fits into the bottom groove.
5. Install the door decorative strip (A) to cover the gap between the top edge of panel (B) and door frame (C). Secure with screws.

CAUTION: DO NOT OVER TIGHTEN SCREWS.



Drawing No: C-16296C

Wiring Diagram DE-704D

LIMITED WARRANTY NORCOLD

P.O. Box 180
Sidney, Ohio 45365

This Limited Warranty is given by NORCOLD, Div. of The Stolle Corporation, ("Company") to the original consumer-purchaser of any new refrigerating equipment ("Equipment") supplied by the Company, excluding glassware and electric light bulbs, and will be effective for a period of one year from date of original purchase. The Company warrants, provided that the Equipment shall at all times have been in possession of and used by the original consumer-purchaser, that:

- A. The Company will provide free service and replacement of defective parts at no charge at all authorized Norcold Service Centers for a period of one year from the date of original purchase. This Limited Warranty covers labor costs incurred in removing and re-installing the refrigerator only when necessary to replace a defective part. The Company will pay inbound and outbound transportation costs of any defective part, for a 1-year period commencing with date of purchase. The original consumer-purchaser must pay all expenses incurred in making the equipment available at one of the Norcold Service Centers.
- B. The following procedure shall be followed by any original consumer-purchaser desiring to obtain performance under the terms of this Limited Warranty. The refrigerator must be brought to any of the Norcold Service Centers and the original consumer-purchaser must present evidence (1) to identify the original consumer-purchaser; and (2) that the item claimed to be defective is still within the warranty coverage. If the original consumer-purchaser is unable to accomplish this task, written notice should be immediately directed to Norcold and advice will be promptly given concerning the manner in which warranty service may be obtained. Inability to physically bring the refrigerator to a Norcold Service Center will not void the warranty, but any additional costs thereby incurred are solely for the account of the original consumer-purchaser.
- C. The Company will not be liable under this Limited Warranty for any of the following:
 - (1) Defects which arise by reason of transit damage, misuse, neglect or accident.
 - (2) Manufacturing defects found at the time of purchase which are not communicated to the Company within 30 days.
 - (3) Defects in glassware and electric light bulbs.
 - (4) Defects arising from improper installation or adjustment of the Equipment.
 - (5) The need for normal maintenance of this refrigerator, including the cleaning of the flue dilution assembly and orifice, and the adjustment of the gas pressure regulator in the case of gas-electric models.
 - (6) Defects arising from the improper use of parts or parts not manufactured or supplied by the Company in the course of repairs or replacements to the Equipment.
- D. Employees and agents of the Company, and its authorized service representatives, have no authority to vary the terms of the Limited Warranty, which applies only to Equipment purchased and installed in the United States of America and the Dominion of Canada. The Company reserves the right to make any improvements or changes in parts of models without notice to any original consumer-purchaser.
- E. The Company shall not be liable or in any way responsible for any loss or damage to person or property, or lost profits or other similar loss or damage that may result or be claimed to have resulted from a defect in any part of the Equipment covered by this Limited Warranty. Some states do not allow the exclusion or limitations of any incidental or consequential damages so the above limitation or exclusion may not apply to you.
- F. ANY IMPLIED WARRANTY OR MERCHANTABILITY OR FITNESS FOR A PARTICULAR PURPOSE:
 - (1) APPLICABLE TO A PART OR PARTS OF THE REFRIGERATOR IS LIMITED TO A PERIOD OF ONE YEAR FROM DATE OF PURCHASE.
 - (2) SOME STATES DO NOT ALLOW LIMITATIONS ON HOW LONG AN IMPLIED WARRANTY LASTS. THE ABOVE LIMITATIONS MAY NOT APPLY TO YOU.
- G. This Warranty gives you specific legal rights, and you may also have other rights which vary from state to state.

SERVICE INFORMATION

**IF SERVICE OR PARTS ARE REQUIRED, CONTACT THE
NEAREST NORCOLD SERVICE CENTER.**

**A NORCOLD SERVICE CENTER BOOKLET HAS BEEN
INCLUDED WITH THE REFRIGERATOR INFORMATION
PACKET.**